

Installation Instructions: Air-Transfer

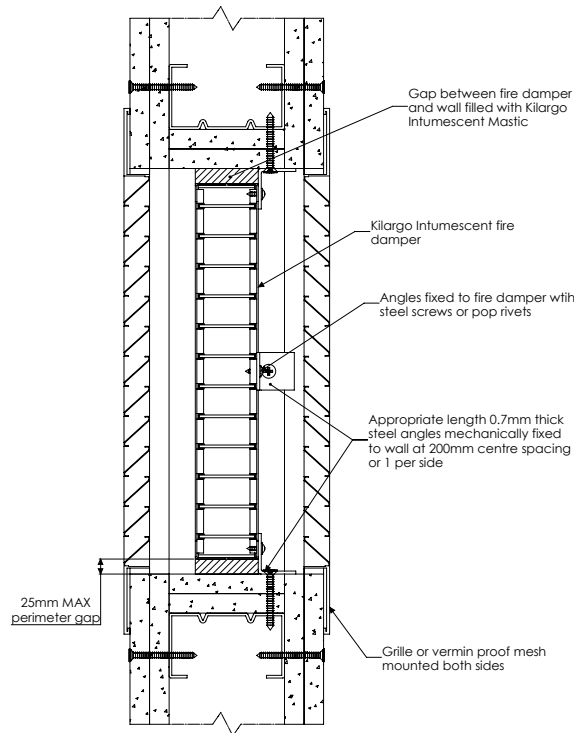

- | | |
|---------------|---|
| Step 1 | Position damper centrally in penetration aperture as per system drawing with temporary supports or packers. |
| Step 2 | Fasten mounting angles or brackets to damper with steel self-drilling screws or steel pop rivets and to the building element with appropriate mechanical fixings as per system drawing. |
| Step 3 | Apply Kilargo Intumescent Mastic (supplied separately) to the gaps between the damper & building element. Ensure fill depth corresponds with those detailed in the system drawing. |
| Step 4 | Ensure product and certification labels are in a prominent position for easy identification during subsequent maintenance inspections. |
| Step 5 | Fix grilles, louvres or vermin proof mesh independently to each side of the building element. |

System Notes

- Grilles, louvres, vermin proof mesh, angles, brackets & fixings are to be supplied by others.
- Grilles to be fixed independently to the building element and shall not be fixed to the fire damper.
- Kilargo Intumescent Fire Dampers shall be installed in accordance with this detail, including the use of Kilargo Intumescent Mastic and in accordance with the requirements of AS1682.2
- Ensure convenient access is provided for visual inspection and cleaning as necessary.
- 2mm Minimum gap allowable between damper and aperture. For gaps between 2-5mm, a fillet of Kilargo Intumescent Mastic shall be applied.

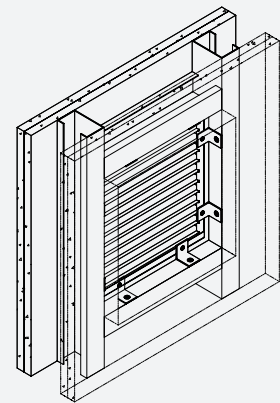

Building element:	FR Plasterboard 2 x 16
Application:	Cell only - Air Transfer with grilles or flat vermin proof mesh
Maximum size:	1200 x 1200
FRL	-/120/120
Test reference No.	FAS200229

System No. WP7i (a)

Installation Instructions: Air-Transfer - Modular

Wall Mounted Systems

U Channel

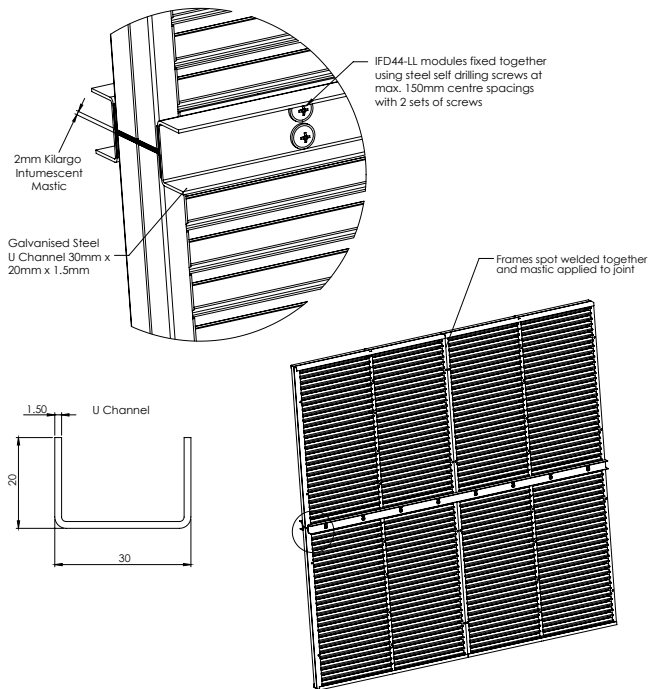

Galvanised Plate

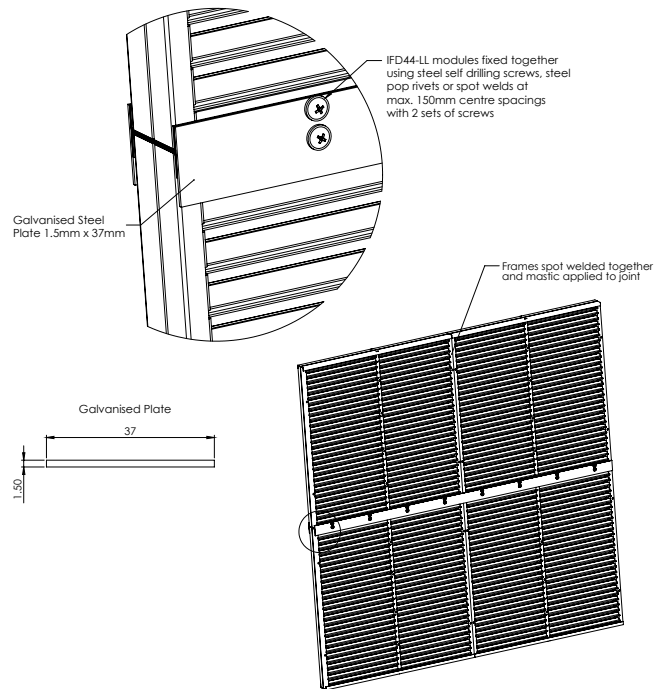

- Step 1** Apply Kilargo Intumescent Mastic to the opposing module.
- Step 2** Align and bring modules together and mechanically fix together using U channels and steel self-drilling screws or steel pop rivets with 2 sets of screws at 150mm centres as per the modular system drawing on both sides.
- Step 3** Fix modular damper to aperture or casing as shown in the appropriate system drawing and installation instructions.

System Notes

- Fixings are to be supplied by others.
- Optional flat joining strips supplied at the time of order in lieu of U channel on request for air transfer systems only.

Alternative Fixing Methods

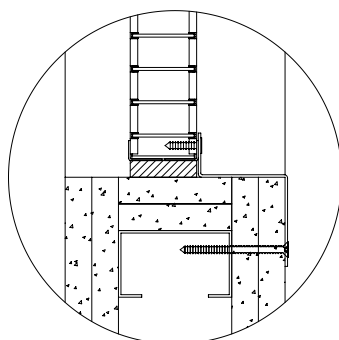

Z Bracket Fixing

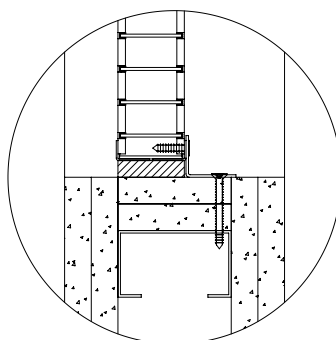

Angle Fixing

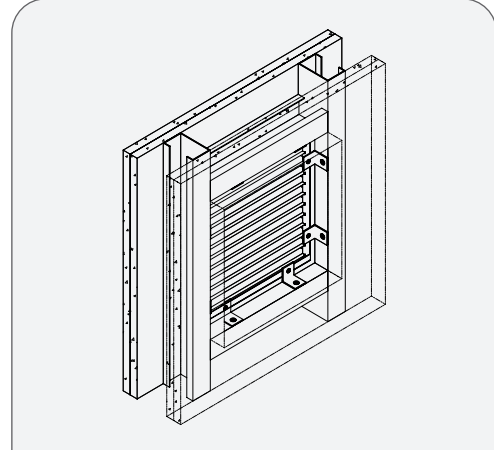

Building element:	FR Plasterboard 2 x 16
Application:	Cell only - Air Transfer with grilles or flat vermin proof mesh
Maximum size:	1200 x 1200
FRL	-/120/120
Test reference No.	FAS200229

Note: To be read in conjunction with system WP7i (a)

System No. WP7i (b)